

1 ELEVATION
 FRAMELESS HINGED PIVOT DOOR W/LEVER SCALE: 1/2"=1'-0"

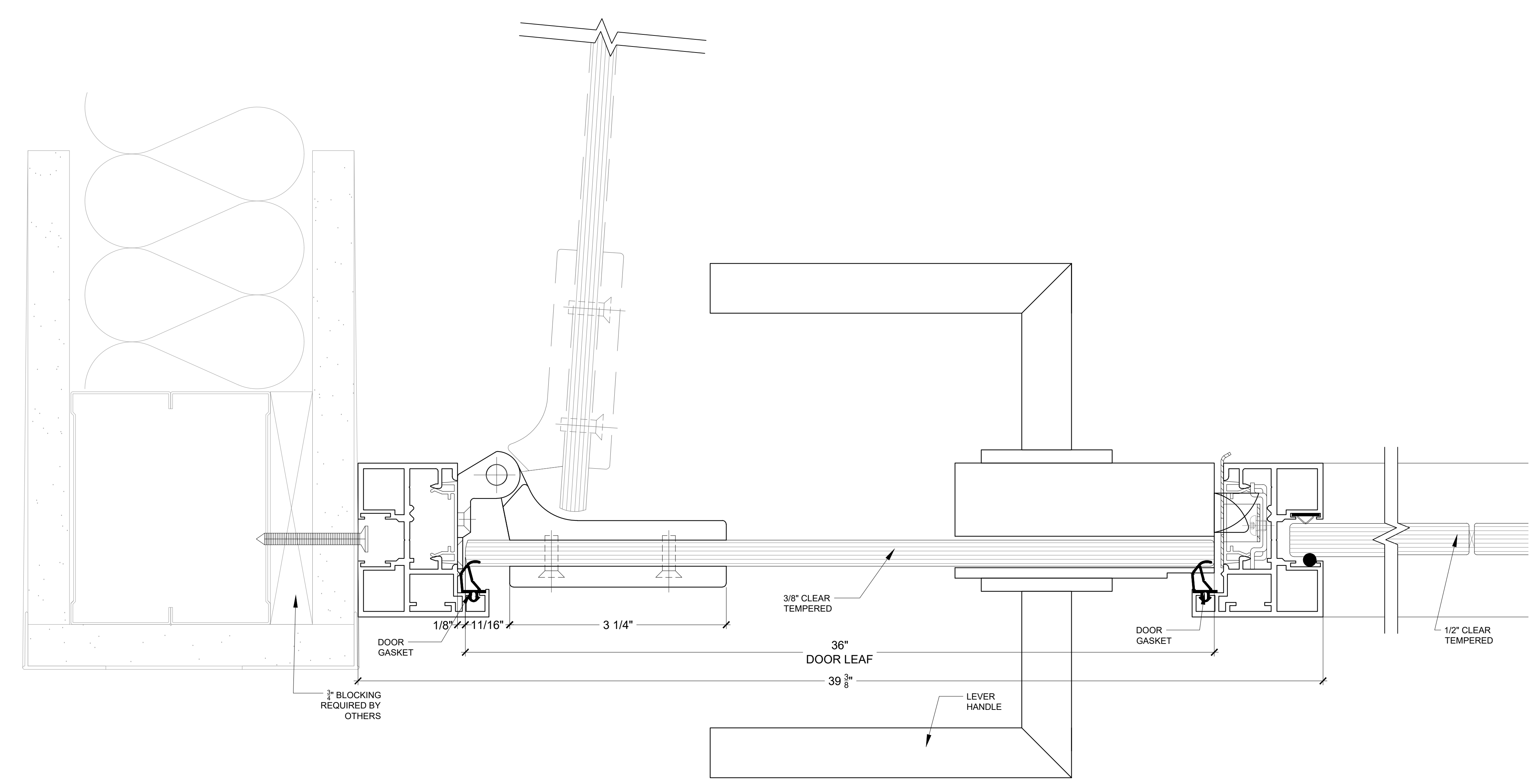

3 FRAMELESS HINGED CENTERED PIVOT DOOR W/ LEVER HANDLE
 1'-0"=1'-0"

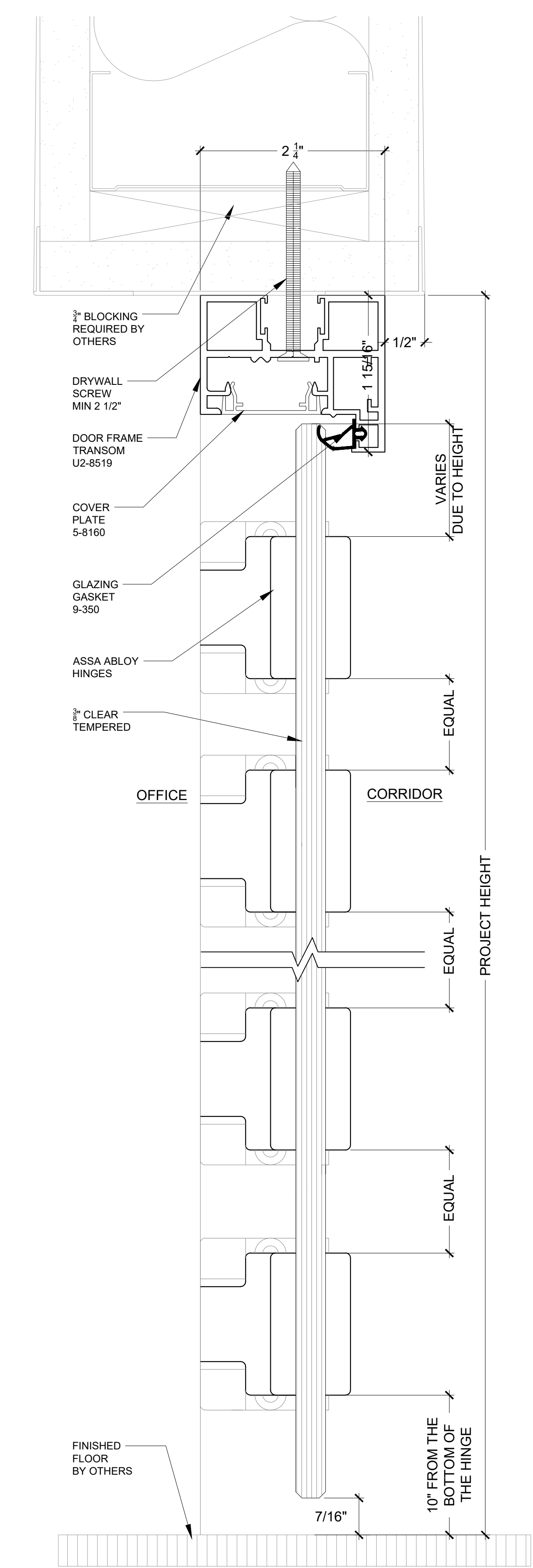

1 FRAMELESS HINGED CENTERED PIVOT DOOR
 1'-0"=1'-0"

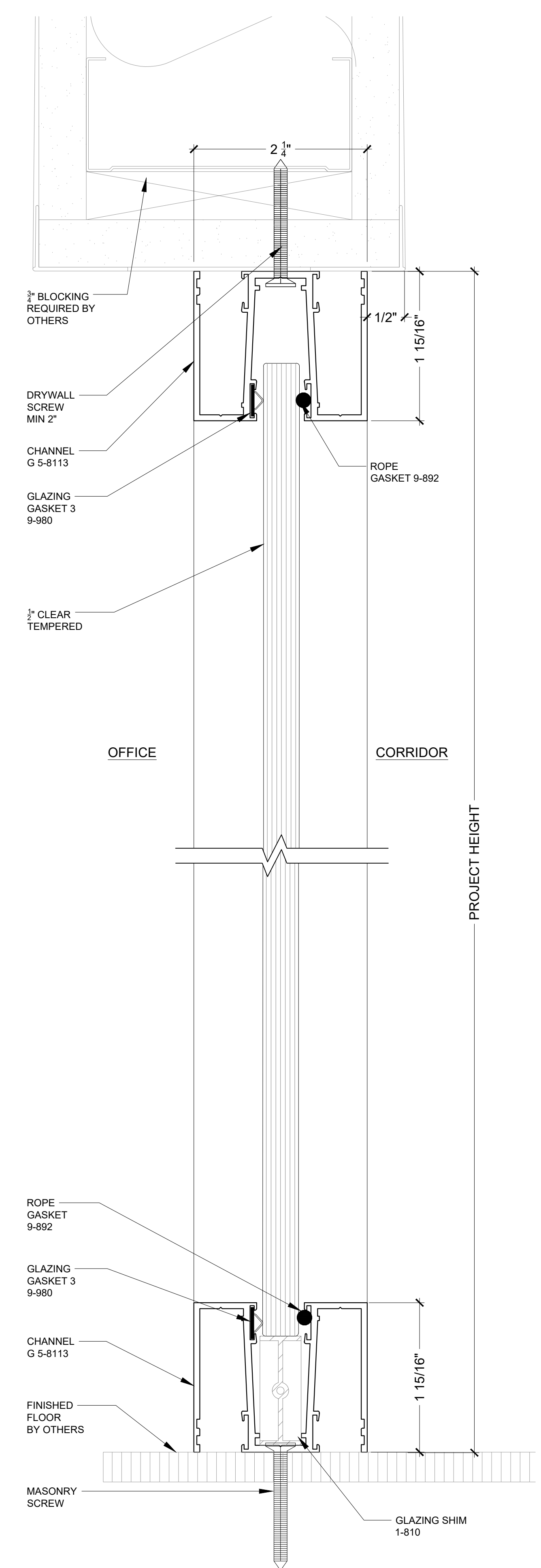

2 CENTERED FIXED CHANNEL
 1'-0"=1'-0"

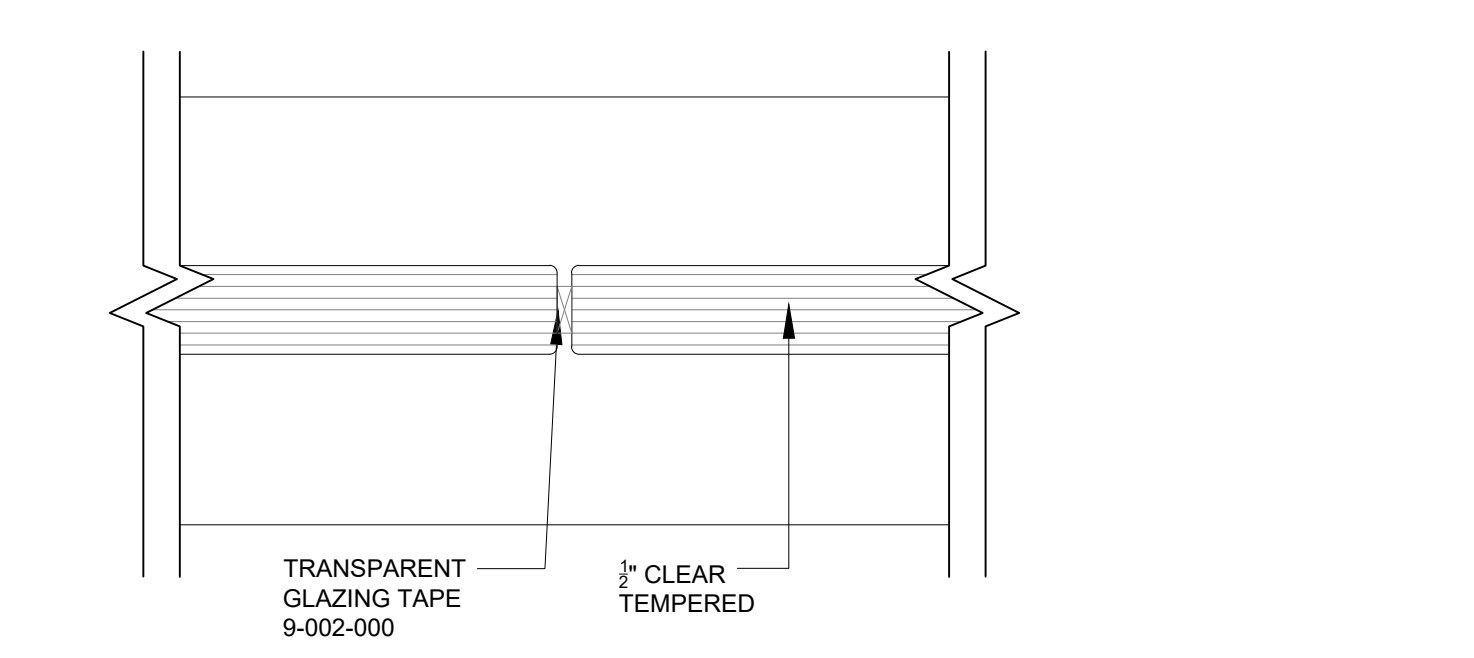

4 GLASS CONNECTION
 1'-0"=1'-0"

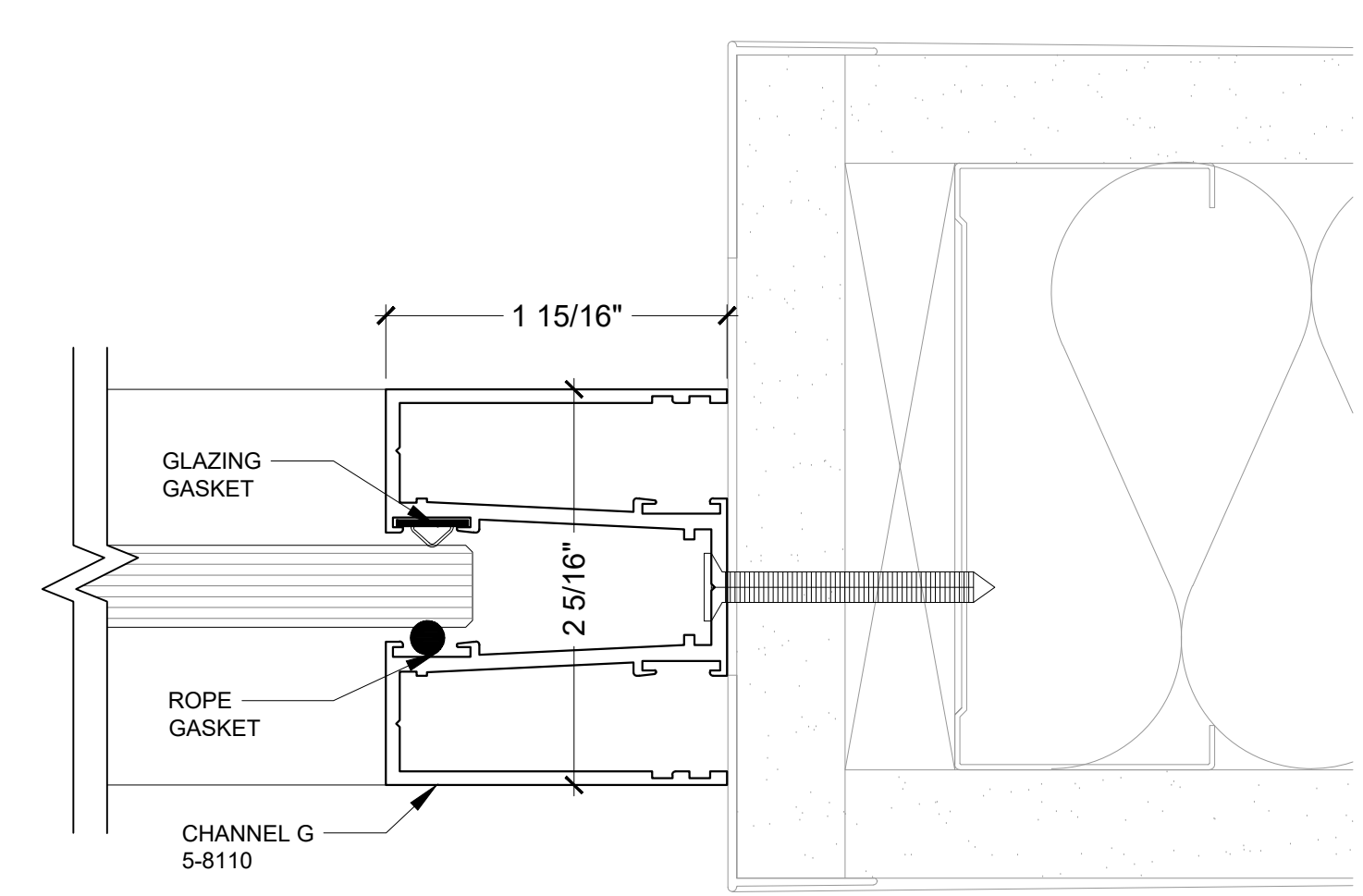

5 WALL ABUTMENT
 1'-0"=1'-0"

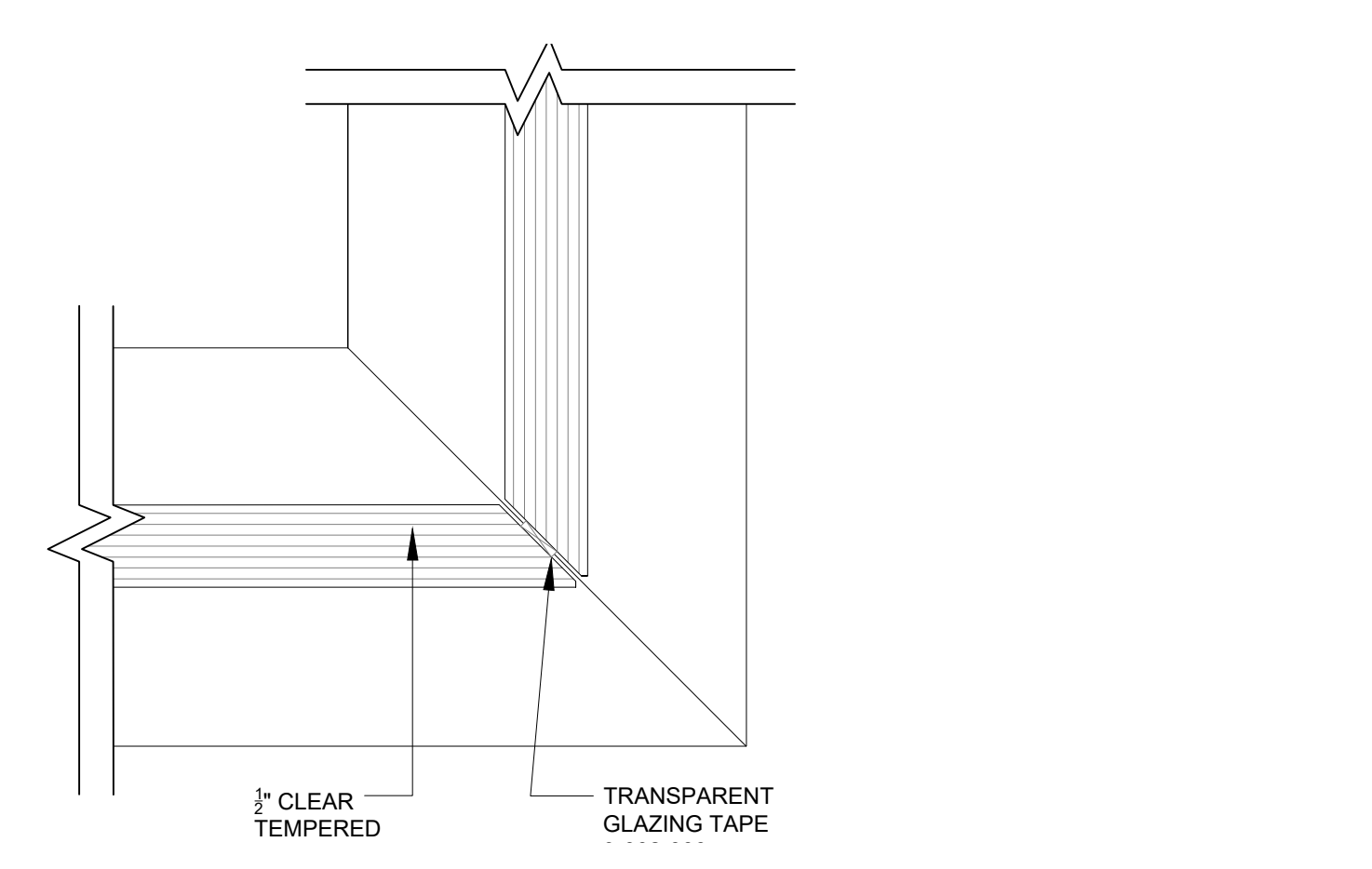

6 GLASS CORNER
 1'-0"=1'-0"

LEGEND:

1	Out for Approval	W.D.2011
No.	REVISED	DATE

Frameless Single Glazed Centered Pivot Door w/ Lever Handle

PROJECT:

CLIPPER STANDARDS DRAWINGS

DRAWING TITLE:
FRAMELESS HINGED CENTER PIVOT W-LEVER

225 Park Avenue South - Suite 201
 New York, NY 10003
 Tel. 212.647.6200
 175 Normansdown Rd. - Ste 2000
 Basking Ridge, NJ 07920
 Tel. 908.901.0001

WWW.WBWOOD.COM
 • New York • New Jersey •

A Herman Miller Certified Network Member

PROJECT No.: _____ JOB No.: _____
 DATE: December 20, 2019
 SCALE: 11 11/16" = 1'-0"
 DRAWN BY: NIP
 CHECKED BY: XXXX

Approved By: _____
 Signature: _____ Date: _____

These plans are an instrument of service and are the property of WB Wood. Infringements will be prosecuted.